



CASE STUDY: EFFECTIVE HRSG CLEANING WITH OFF-LINE EPIC™ SHOCKWAVE TECHNOLOGY

Date: Spring 2020

Facility: Large Combined Cycle Plant in Central Florida

Type of Equipment: Nooter/Eriksen HRSG

Technology: EPIC™- Extraction Pressure Impulse Cleaner

INTRODUCTION

This HRSG case study covers details, observations and the processes resulting in a 4-inch reduction in combustion turbine back pressure at a major combined cycle utility station utilizing the proprietary EPIC™ cleaning system. Backed by 33 years solely in the industrial cleaning business, the service was provided by Thompson Industrial Services, accompanied by PowerPlus Cleaning Systems, inventor of the EPIC technology.

OBJECTIVE

The objective of the cleaning was to remove surface and embedded operational deposits accumulated within the tightly spaced harp tubes from the inlet side of the HP Economizer #2 to the downstream side of the FW Heater #1 bundle. By removing those deposits, which restrict gas flow and adversely insulate crucial heat transfer surfaces, the unit would realize a significant decrease in combustion turbine back pressure and restore operating efficiency to optimize overall HRSG performance.

DESCRIPTION OF THE CLEANING TECHNOLOGY

The proprietary EPIC cleaning system utilizes shockwave displacement energy generated from the patented IMPULSE® cleaner to safely and effectively concentrate a repeated series of dynamic high-pressure cleaning pulses *directly and deeply into the tube bank*. The cleaning is coordinated via a remotely controlled navigation system with all personnel located safely outside of the HRSG unit.

IMPULSE® shock wave device and directional shroud assembly are remotely maneuvered horizontally and vertically over tube bank surfaces

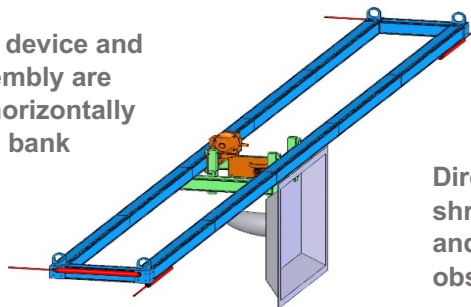

Remote navigation controller

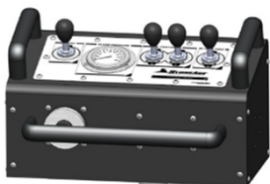

Directional shroud indexes in and out to avoid obstructions

Areas of platenization between finned tubes

Shockwaves create deep & encompassing cleaning energy

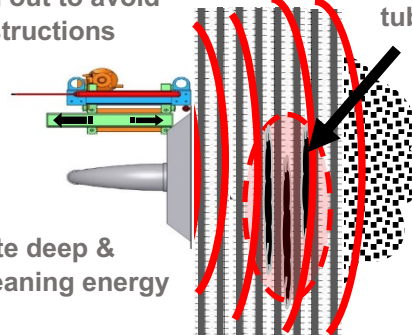

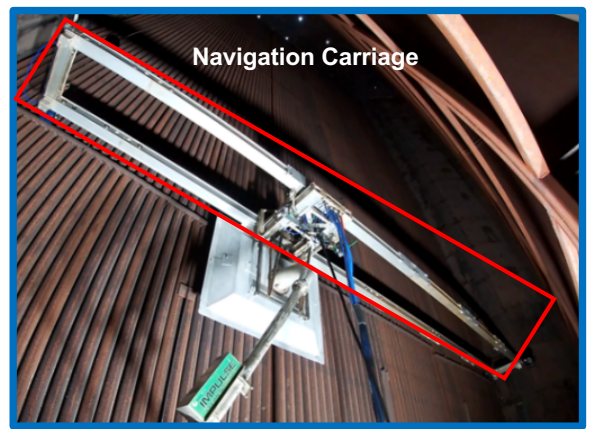

CLEANING PERFORMANCE ENHANCEMENTS

The automated and remotely operated EPIC cleaning system is extremely safe for personnel as well as the entire HRSG structure with numerous fail-safe features fully integrated into the overall process. Other unique high-tech features of the EPIC process include:

- Real time observation of the cleaning progression from 6 system cameras monitored within the ground level command center on a large screen display.
- Progressive back pressure reduction of each segment, as its being cleaned, is also captured and trended in the control module.



Besides these monitoring capabilities,

- Before and after borescope videos are provided for review as well.
- In most applications, depending on access and permission granted, multiple pneumatic vibrators can be utilized on the lower header(s) while conducting the EPIC cleaning, providing a subtle additional motivation of dislodged material to drop to grade level for its removal.
- Visual proof of the overall effectiveness is also possible in most HRSGs with optional before and after drone inspections and videos of all panels.

DESCRIPTION OF THE SUBJECT APPLICATION

The HRSG was manufactured by Nooter/Eriksen, which consisted of 6 separate finned tube bundles downstream of the SCR. The panels were approximately 65 feet high by 32 feet across. The space between tube bundles ranged from approximately 32" to 48". Entry into the HRSG was through small 18" x 24" access doors near grade level.

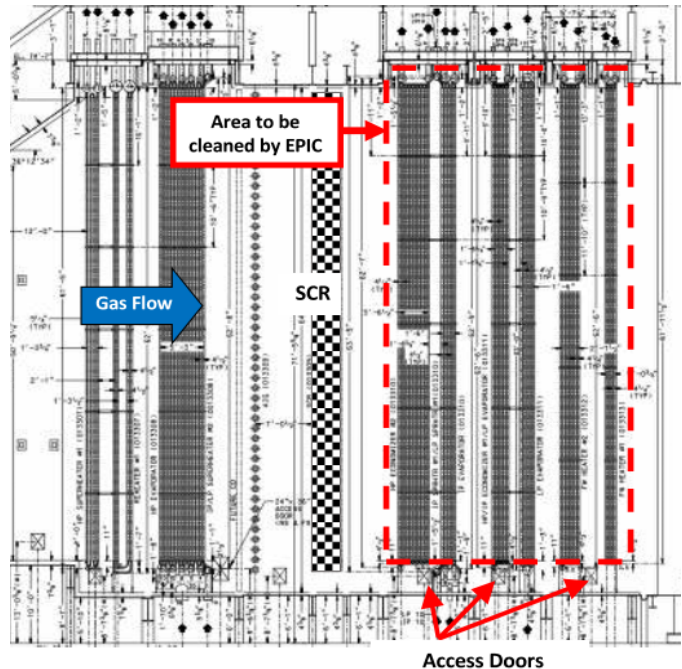

OVERVIEW

The EPIC™ cleaning system effectively dislodged and removed the deep and heavily impacted deposits that had accumulated on and within the finned tube surfaces of the HRSG. The service required five (5) day-shifts of operation with a singular crew, which included setup and dismantling, with coordinated off-shift vacuuming by Thompson's own personnel and equipment to remove the considerable amount of dislodged debris.

RESULTS

The post-cleaning visual inspection of facial surfaces from numerous vantage points throughout the HRSG, complimented by penetrating in-depth videoing into multiple harp panels by borescope, combined to provide empirical evidence of the EPIC cleaning effectiveness. Subsequently the operating performance was later tabulated and evaluated by plant engineering and management personnel resulting in comments such as one from the Operations Manager being “thrilled” with the results and the Plant Manager enthusiastically stating “EPIC is the way to go to clean our HRSGs and we’ll use it again in the spring for our next one.”

Based on 6-month comparative operating data that was voluntarily shared with Thompson, it was determined that the **combustion turbine back pressure was reduced by 4 inches of water column, resulting in a heat rate decrease by roughly 0.5 MMBtu/MWh. This was computed to yield an equivalent payback in 1,018 hours (41 days) due to reduced fuel costs, based on a 100% production (MW) load.**

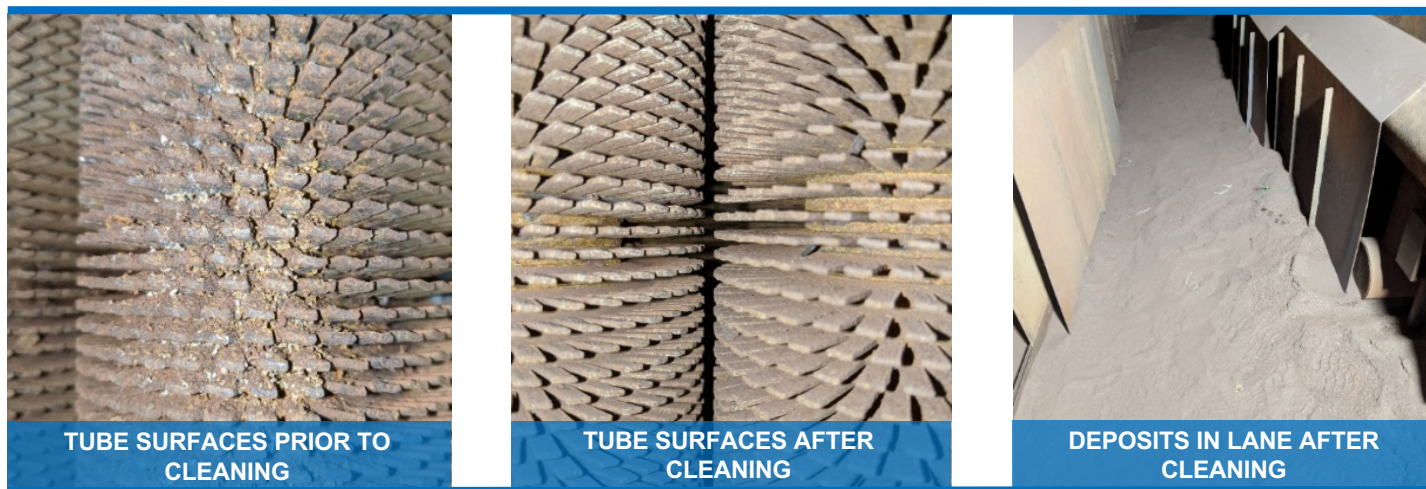

CONCLUSION

Implementation of this EPIC off-line application, solidly based on 14-years of proven on-line pulse-detonation shockwave boiler and HRSG cleaning technology, can deliver dramatic 360 degree results *focused solely on the fouled heat transfer surfaces* within a HRSG. When compared to other existing cleaning methods, the EPIC process does not require expensive and time-consuming erection of scaffolding, spreading of tubes or hundreds of repeated insertion and detonations of gas bags in the voids between the bundles. In summary, as exemplified in this case study, the EPIC technology and ultra-safe cleaning process can achieve substantial CT efficiency enhancements, reduce operating cost and shorten outage durations.

For more information, visit www.ThompsonIndustrialServices.com, call (800) 849-8040 or email Carl Wise at cwise@thompsonind.com